

FOCUS ON NIKOLATESLA



Aprendo il coperchio si ha la possibilità di rimuovere le quattro batterie di filtro ceramico (rigenerabile) ad altissime prestazioni e di svuotare il vano di sicurezza raccolta liquidi, l'unico in grado di proteggere il motore in caso di fuoriuscita di liquidi derivanti dalla cottura.

By opening the cove, you can remove the four batteries of the high performance ceramic filter (regenerable) and empty the liquid collection safety compartment, which is the only component that can protect the motor in case of leakage of cooking liquids.



Rimuovendo la griglia si accede comodamente al filtro grassi alluminio per permetterne una facile pulizia.

By removing the grid, you can easily reach the aluminum grease filter thus performing easy cleaning.

La valvola di scarico per la fuoriuscita abbondante di liquidi assicura un'ulteriore sicurezza igienica.

The drain valve guarantees cleanliness also in the case of abundant overflow of liquids.



NikolaTesla è stato pensato per garantire la massima flessibilità di installazione per l'ottimizzazione degli spazi interni del cabinet grazie a una tubazione posteriore mobile e posizionabile sempre a ridosso dello schienale per consentire l'utilizzo di cassetti più profondi e spaziosi.

NikolaTesla has been conceived to guarantee maximum installation flexibility, in order to best use the cabinet internal spaces, thanks to a movable rear piping, which can be positioned close to the back, allowing for the use of deeper and more spacious drawers.

NIKOLATESLA VERSIONI ASPIRANTE STANDARD NikolaTesla standard Duct out modes

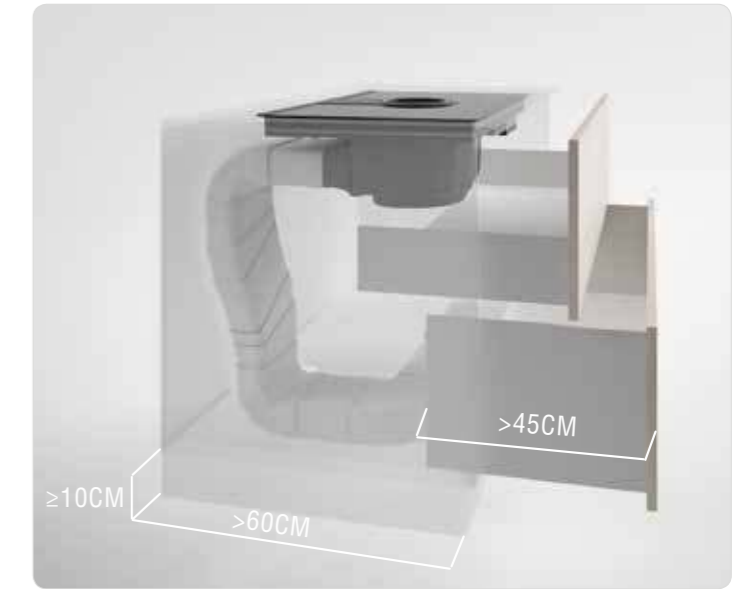
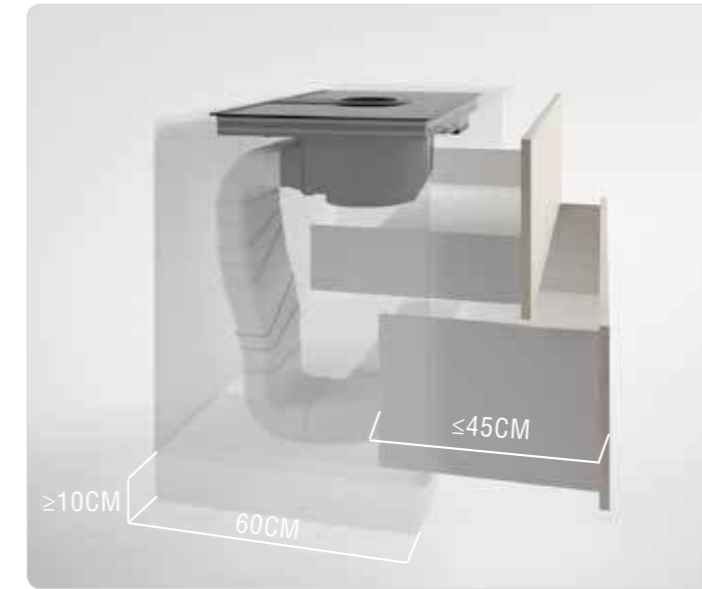

NIKOLATESLA VERSIONI FILTRANTI STANDARD NikolaTesla standard Recycling modes

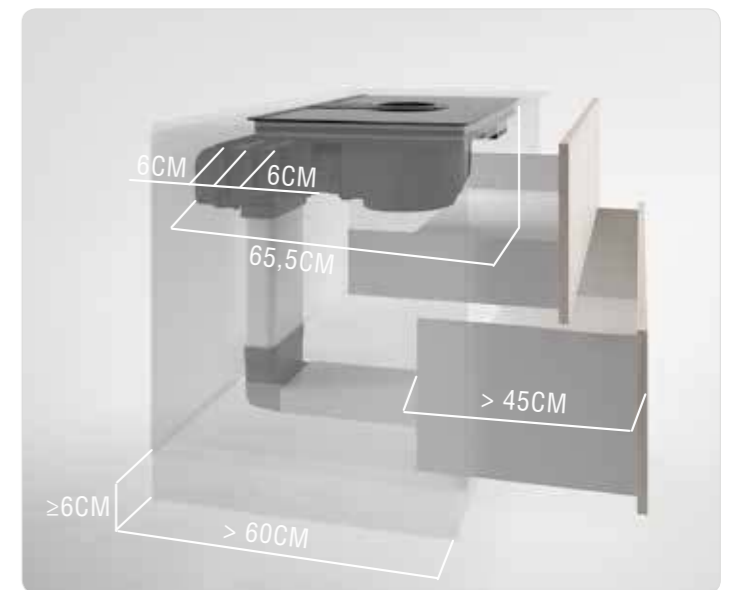
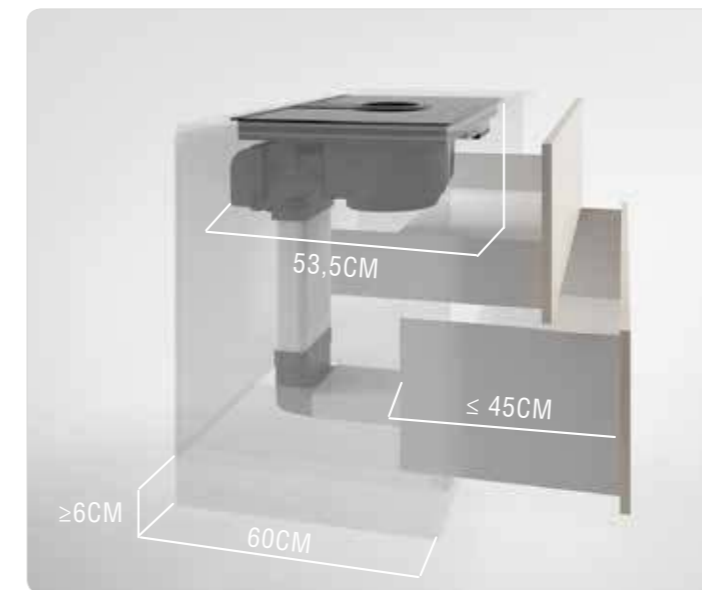

FOCUS ON NIKOLATESLA

NikolaTesla è stato ideato per adattarsi a molteplici tipologie di cucina. Nella versione filtrante standard NikolaTesla è dotato di tutto l'occorrente per essere installato, incluso l'esclusivo profilo cromato che rifinisce il taglio dello zoccolo necessario per l'uscita dell'aria. Nella versione aspirante le tubazioni sono accessori e l'utente potrà scegliere la configurazione ideale in base alle proprie esigenze architettoniche. È possibile installare nikolatesla in appoggio diretto sul piano di lavoro (standard) o inserito in un'alloggiamento senza discontinuità con il top (filotop).

NikolaTesla has been designed to fit into many different types of kitchens. In the standard filtering version, NikolaTesla is equipped with every component needed for installation, including the exclusive chrome-plated profile that finishes the air outlet hole at baseboard. In the aspiration version, pipes are supplied as accessories and users can choose the best configuration solution, based on the architecture of their home. It is possible to install nikolatesla directly against the countertop (standard) or inserted in a slot, blending in with the countertop. (Filotop).

NIKOLATESLA LIBRA / ONE / PRIME / SWITCH / UPSIDE

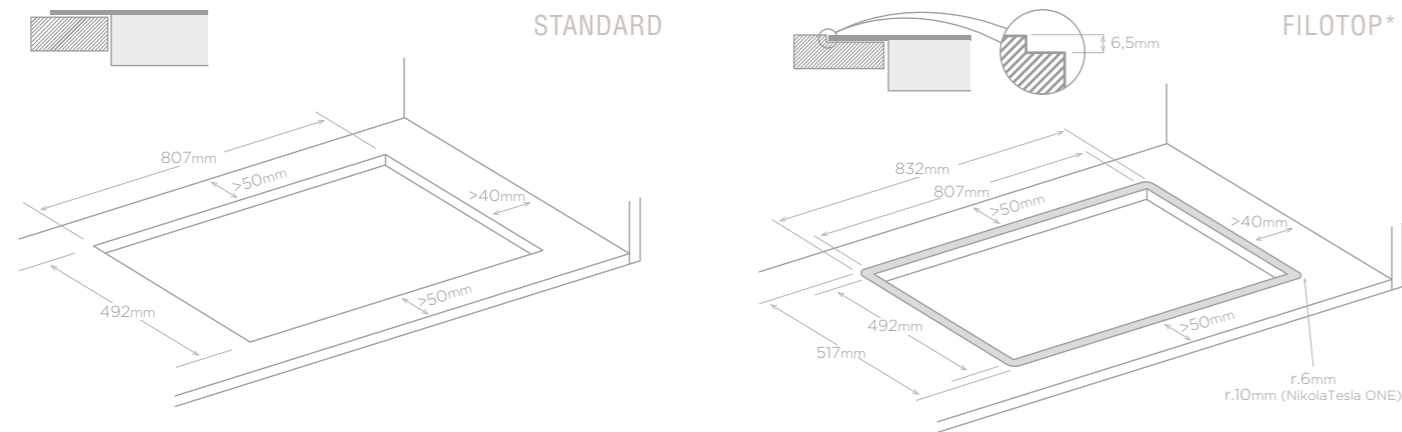

NIKOLATESLA FLAME

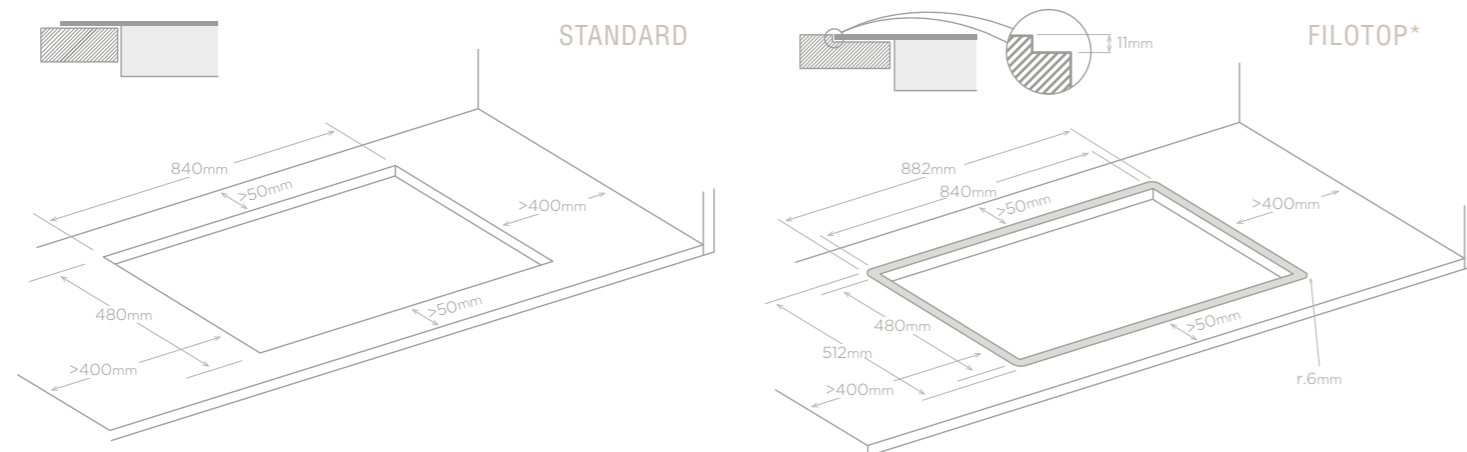

* Dimensioni consigliate filotop: per tolleranze differenti, attenersi alla reale dimensione del vetro.
 * Recommended filotop dimensions: for different tolerances, respect the actual dimensions of the glass.
 PER ULTERIORI APPROFONDIMENTI CONSULTARE IL MANUALE DI INSTALLAZIONE DEL PRODOTTO.
 FOR FURTHER INFORMATION, CONSULT THE PRODUCT INSTALLATION MANUAL.

NELLA SCATOLA

NikolaTesla è fornito già completo per essere installato (nelle versioni standard) sia in aspirante che in filtrante. Di seguito sono riportate le configurazioni consentite con i componenti a corredo nell'imballo. Per altre esigenze di montaggio sono a disposizione, come accessori, curve e tubazioni.

IN THE BOX

NikolaTesla includes everything it needs (in the standard version) for being installed in both aspiration and filtering version. Possible configurations, and related components included in the packaging, are mentioned below. For any other installation needs, bends and pipes are available as accessories.

NIKOLATESLA VERSIONE ASPIRANTE STANDARD
 NikolaTesla standard Duct-out mode



NIKOLATESLA VERSIONI FILTRANTI STANDARD
 NikolaTesla standard Recycling modes



Accessori di installazione a pag. 232
 Installation accessories on page 232

MODALITÀ DI INSTALLAZIONE ASPIRANTE DUCT-OUT INSTALLATION MODES

I vapori di cottura sono convogliati all'esterno attraverso tubazioni di ingombro ridotto che sfruttano lo spazio presente sotto le basi purché l'altezza dello zoccolo sia almeno 100 mm.

Cooking vapors are conveyed to the outside by means of compact pipes that pass into the free space found under the bases, provided that the base board height is at least 100 mm.



MODALITÀ DI INSTALLAZIONE FILTRANTE RECYCLING INSTALLATION MODES

Grazie alle speciali componenti Elica l'installazione può essere realizzata anche su cucine il cui zoccolo ha un'altezza almeno di 60 mm.

Thanks to the special components provided by Elica, installation is also possible in kitchens whose base board is 60 mm high.

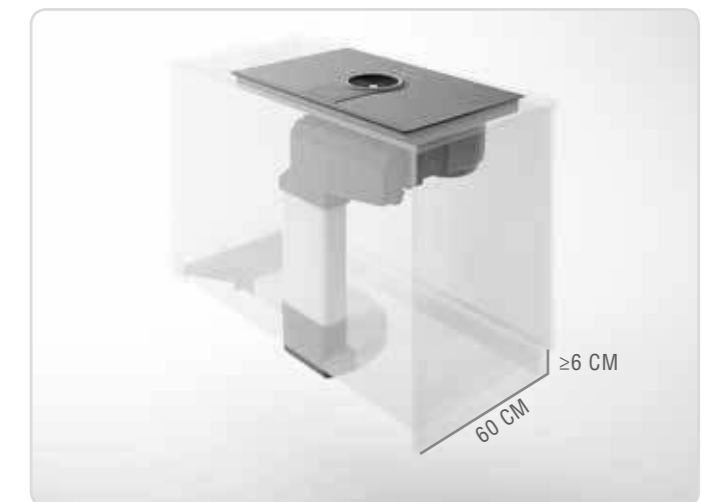
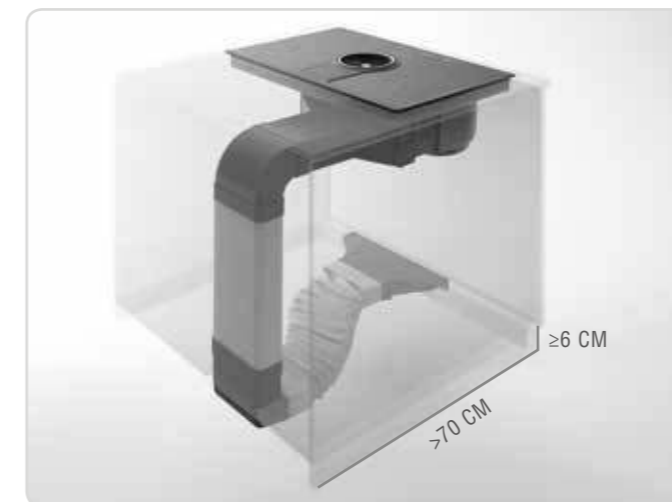
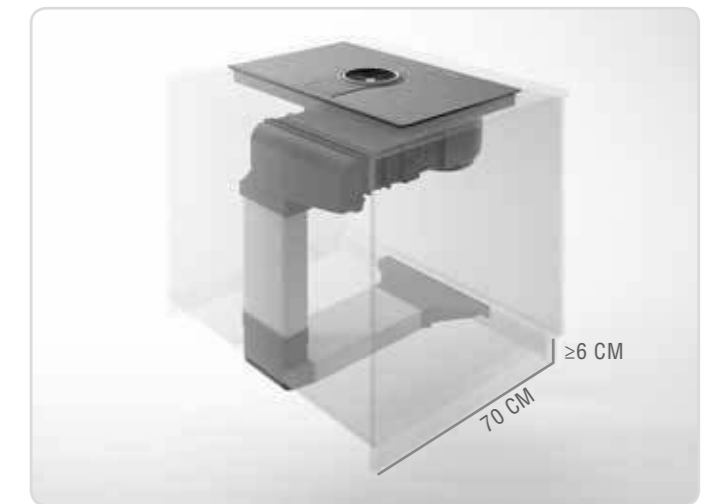

Accessori di installazione a pag. 232
Installation accessories on page 232

WALL

Qualsiasi parete assume le sembianze e il simbolismo di un totem.
C'è una forza mistica nelle forme di Haiku, unite alla sua tecnologia di ultima generazione.

Any wall can take on the appearance and the symbolism of a totem.
There is a mystical strength in the shape of the Haiku, together with its latest generation technology.





AWARDS



HAIKU
DESIGN FABRIZIO CRISÀ

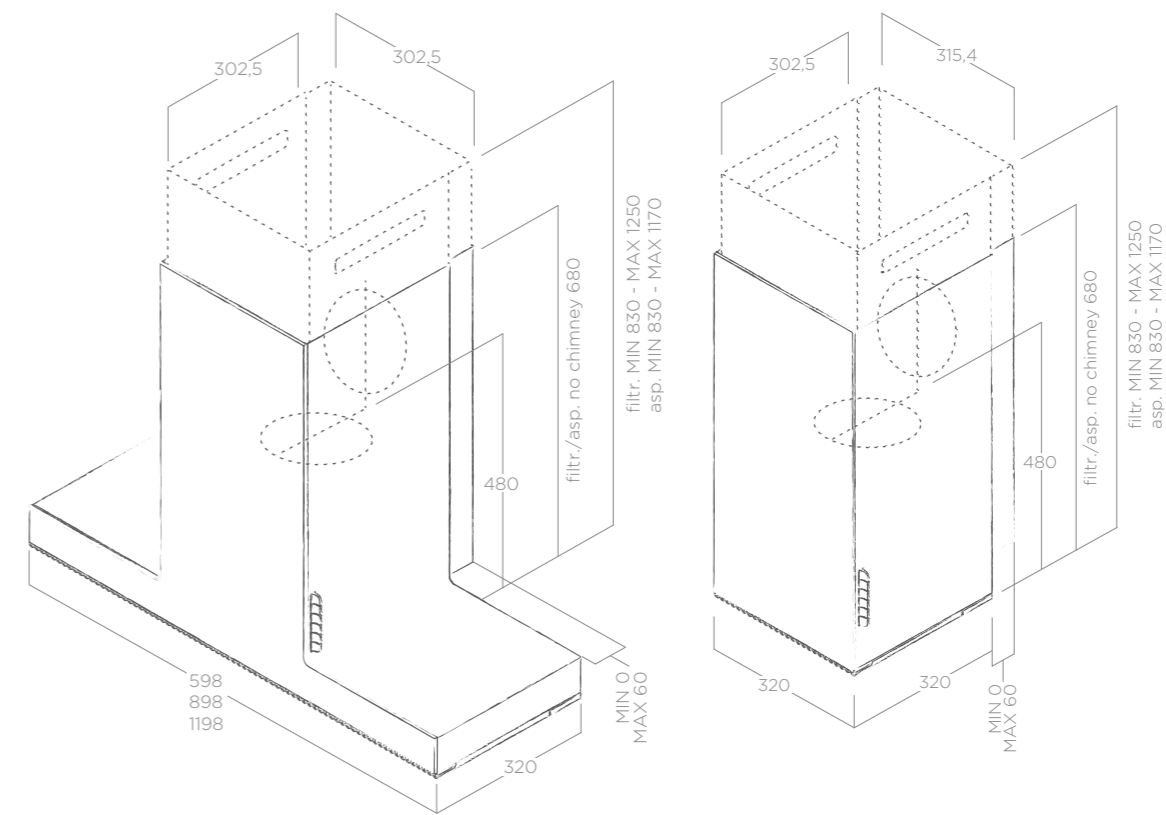

VERSIONE A ISOLA PAG. 127

SCHEDA TECNICA TECHNICAL FEATURES

Misure Size	32 - 60 - 90 - 120 cm
Versione Version	Aspirante Duct-out
Finiture Finish	Vetro nero, Krion bianco, Gres effetto cemento, Acciaio inox Black glass, white Krion, cement effect stonewear, stainless steel

ACCESSORI ACCESSORIES	
Filtro carbone Charcoal Filter	CFC0141529
Filtro lunga durata Long Life Filter	CFC0141725

Approfondimento a pagina seguente
More details on next page

ILLUMINAZIONE LIGHTING	
Tipo Type	Strip Led 1x7 W
Intensità Intensity	281 LUX
Temperatura Temperature	3500 K

MODELLI MODELS	
HAIKU BL/A/32	PRF0146263
HAIKU WH/A/32	PRF0146267
HAIKU CONCRETE/A/32	PRF0146258
HAIKU IX/A/32	PRF0146254
HAIKU BL/A/60	PRF0146264
HAIKU WH/A/60	PRF0146268
HAIKU CONCRETE/A/60	PRF0146259
HAIKU IX/A/60	PRF0146255
HAIKU BL/A/90	PRF0146265
HAIKU WH/A/90	PRF0146269
HAIKU CONCRETE/A/90	PRF0146260
HAIKU IX/A/90	PRF0146256
HAIKU BL/A/120	PRF0146266
HAIKU WH/A/120	PRF0146270
HAIKU CONCRETE/A/120	PRF0146261
HAIKU IX/A/120	PRF0146257

PERFORMANCE PERFORMANCE	
Comandi Controls	Touch Control 3V+2I 3S+2B Touch Control
Portata intensiva Booster airflow	710 m ³ /h
Livello sonoro Noise level	52 db(A)
Assorbimento totale Total absorption	260 W
Uscita Duct size	150 mm
Classe energetica Energy class	A (A+/E)

Possibilità di installazione, in modalità aspirante o filtrante, senza ausilio del camino superiore, restando in un'altezza di 680 mm
Possibility for installation in extraction or filtration mode, without the aid of the upper chimney, remaining within a height of 680 mm

Filtro grassi alluminio incluso Grease aluminium Filter included



SILENCE



SPECIAL MATERIAL



ENERGY CLASS

ARMONIA E SEMPLICITÀ
HARMONY AND SIMPLICITY



La linearità estetica prende forma nelle griglie in alluminio effetto ghisa che caratterizzano fortemente il prodotto. Sono facili da rimuovere e dotate di un sistema di bloccaggio ideato per evitare ogni possibile caduta accidentale. La proposta dei materiali e delle superfici continue permettono una pulizia veloce ma efficace, anche dopo le cotture più ricche.

The aesthetic linearity can be seen in the cast iron effect aluminium grilles, which strongly characterise the product. They are easy to remove and are equipped with a blocking system designed to avoid accidental falls. The proposed materials and continuous surfaces allow fast and efficient cleaning, even after more intense cooking sessions.



VISIONI METRICHE

Haiku, grazie alla varietà di dimensioni proposte, è perfetta per diverse soluzioni progettuali. È disponibile sia nella versione a parete (32, 60, 90 e 120cm) che a isola (32, 120, 180cm), nelle modalità aspirante e filtrante.

METRIC VISIONS

Thanks to the sizes in which it is proposed, Haiku is perfect for a range of design solutions. It is available in both a wall-mounted version (32, 60, 90 and 120 cm) and island version (32, 120, 180 cm), in both an extractor and filtration version.

SHIFT 3238 SYSTEM

L'UNICO SISTEMA A
PROFONDITÀ REGOLABILE

Elica, per prima sul mercato, propone per Haiku SHIFT 3238 un sistema innovativo di staffe a muro, grazie al quale le operazioni di installazione si semplificano. Sarà possibile scegliere la posizione di Haiku per averla in linea con i pensili o per aumentare lo spazio di azione sul piano cottura. SHIFT 3238 permette al corpo cappa di regolare millimetricamente la sua profondità. I vincoli semplicemente spariscono e si moltiplicano le soluzioni estetiche e i vantaggi nelle operazioni di pulizia.

THE ONLY SYSTEM WITH
ADJUSTABLE DEPTH

Elica was the first in the market to propose an innovative wall-mounted bracket system in Haiku SHIFT 3238, thanks to which installation operations have been largely simplified. Haiku can be positioned either in line with the shelves or in such a way as to increase the work space on the hob. SHIFT 3238 allows the millimetric adjustment of the hood body depth. Limitations simply disappear and aesthetic solutions multiply, as do the advantages of cleaning operations.

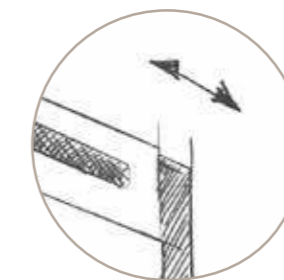





AWARDS



reddot design award
winner 2017



DESIGN
AWARD
2017



GOLD WINNER



INTERIOR
INNOVATION
selection

BIO

DESIGN FABRIZIO CRISÀ

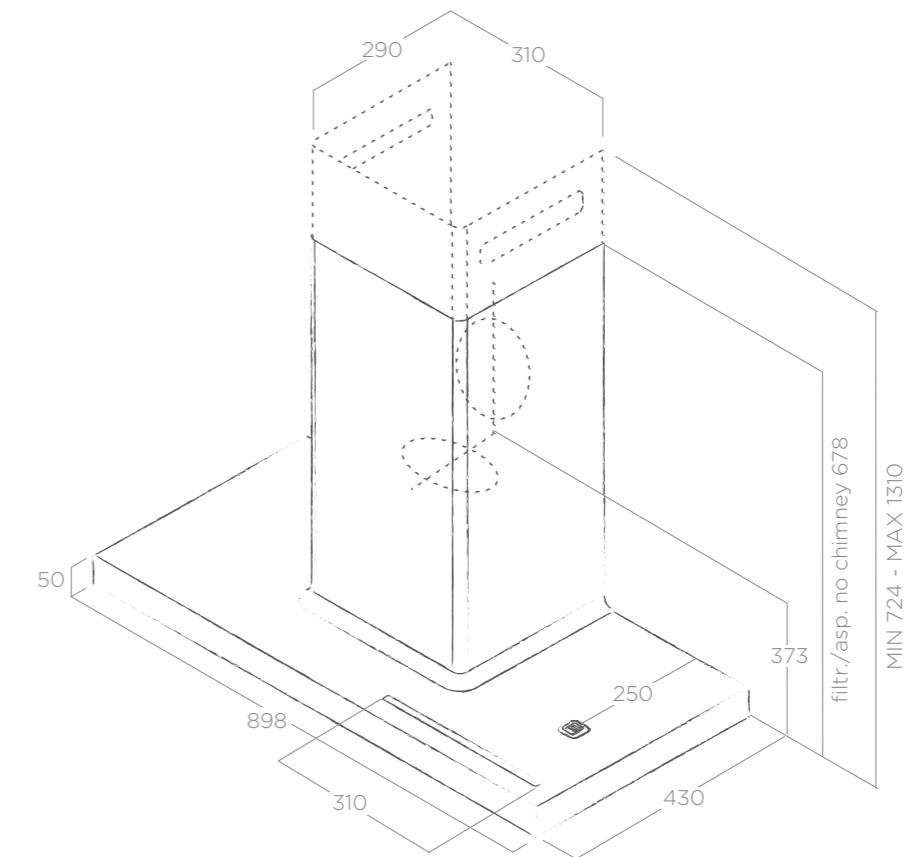

VERSIONE A ISOLA PAG. 133



LIGHTING



SILENCE



SPECIAL
MATERIAL



ENERGY
CLASS

SCHEDA TECNICA TECHNICAL FEATURES

Misure Size	90 cm
Versione Version	Aspirante Duct-out
Finiture Finish	Rovere naturale + bianco effetto soft touch Natural oak + white soft touch effect

ILLUMINAZIONE LIGHTING

Tipo Type	Strip Led 1x7 W
Intensità Intensity	141 LUX
Temperatura Temperature	2700-6000 K

PERFORMANCE PERFORMANCE

Comandi Controls	Touch Control 3V+2I 3S+2B Touch Control
Portata intensiva Booster airflow	757 m ³ /h
Livello sonoro Noise level	60 db(A)
Assorbimento totale Total absorption	317 W
Uscita Duct size	150 mm
Classe energetica Energy class	A+ (A**/E)

ACCESSORI ACCESSORIES

Kit mensola 60cm Shelf kit 60cm	KIT0120946
Radiocomando bianco White remote control	KIT0121468
Radiocomando nero Black remote control	KIT0121469
Revolution filter Revolution filter	CFC0140091
Kit prima installazione filtrante First installation recycling kit	KIT0160440

Radiocomando a richiesta. Estetiche disponibili a pag. 235.
Kit remote control optional. See page 235 for available design.

Kit mensola a pag. 224
Shelf kit on page 224

Supporto e presa USB per la ricarica del tablet.
Support and USB outlet to charge a table.

Possibilità di installazione, in modalità aspirante o filtrante, senza ausilio del camino superiore, restando in un'altezza di 678 mm
Possibility for installation in extraction or filtration mode, without the aid of the upper chimney, remaining within a height of 678 mm

MODELLI MODELS

Filtro grassi alluminio incluso Grease aluminium Filter included

BIO WH/A 90 ROVERE

PRF0147266







THIN

DESIGN FABRIZIO CRISÀ

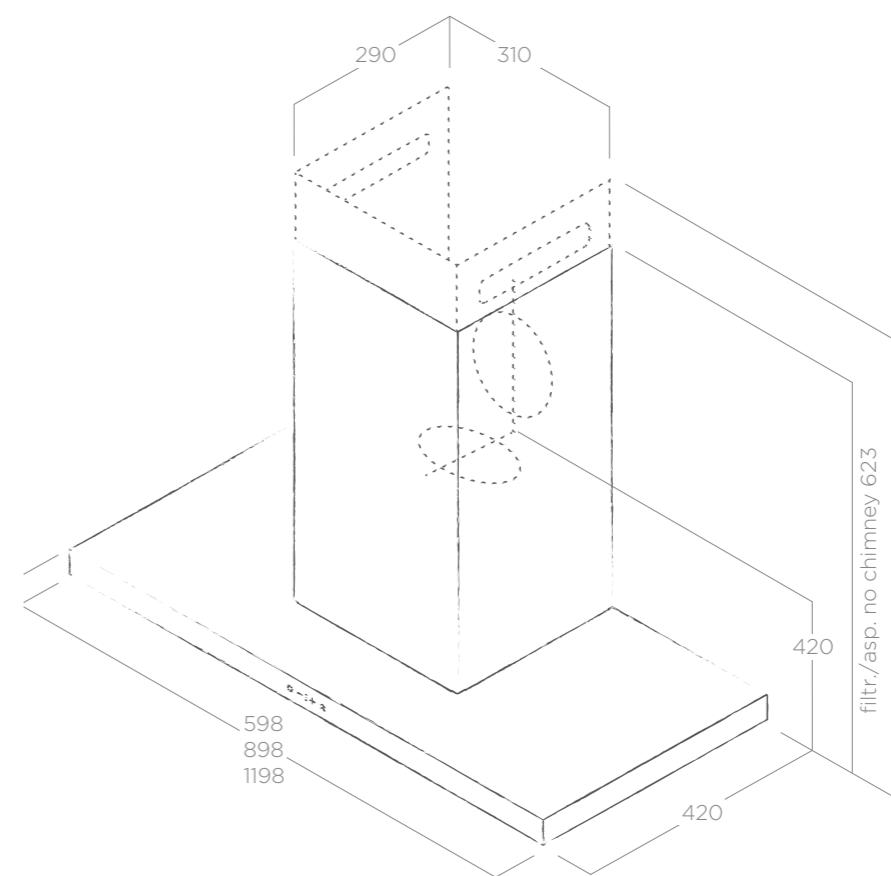

VERSIONE A ISOLA PAG. 135



SILENCE



SMART
INSTALLATION



ENERGY
CLASS

SCHEDA TECNICA TECHNICAL FEATURES

Misure Size 60 - 90 - 120 cm
Versione Version Aspirante Duct-out
Finiture Finish Acciaio inox
Stainless steel

ILLUMINAZIONE LIGHTING

Tipo Type Strip Led 1x7 W
Intensità Intensity 281 LUX
Temperatura Temperature 3500 K

PERFORMANCE PERFORMANCE

Comandi Controls Touch Control 3V+2I
3S+2B Touch Control
Portata intensiva Booster airflow 710 m³/h
Livello sonoro Noise level 54 db(A)
Assorbimento totale Total absorption 317 W
Uscita Duct size 150 mm
Classe energetica Energy class A (A**/E)

ACCESSORI ACCESSORIES

Filtro carbone Charcoal Filter CFC0141529
Filtro lunga durata Long Life Filter CFC0141725



Possibilità di installazione, in modalità aspirante o filtrante, senza ausilio del camino superiore, restando in un'altezza di 623 mm
Possibility for installation in extraction or filtration mode, without the aid of the upper chimney, remaining within a height of 623 mm

MODELLI MODELS

THIN IX/A/60 PRF0144970
THIN IX/A/90 PRF0144969
THIN IX/A/120 PRF0144972

Filtro grassi alluminio incluso Grease aluminium Filter included



METEORITE

DESIGN FABRIZIO CRISÀ

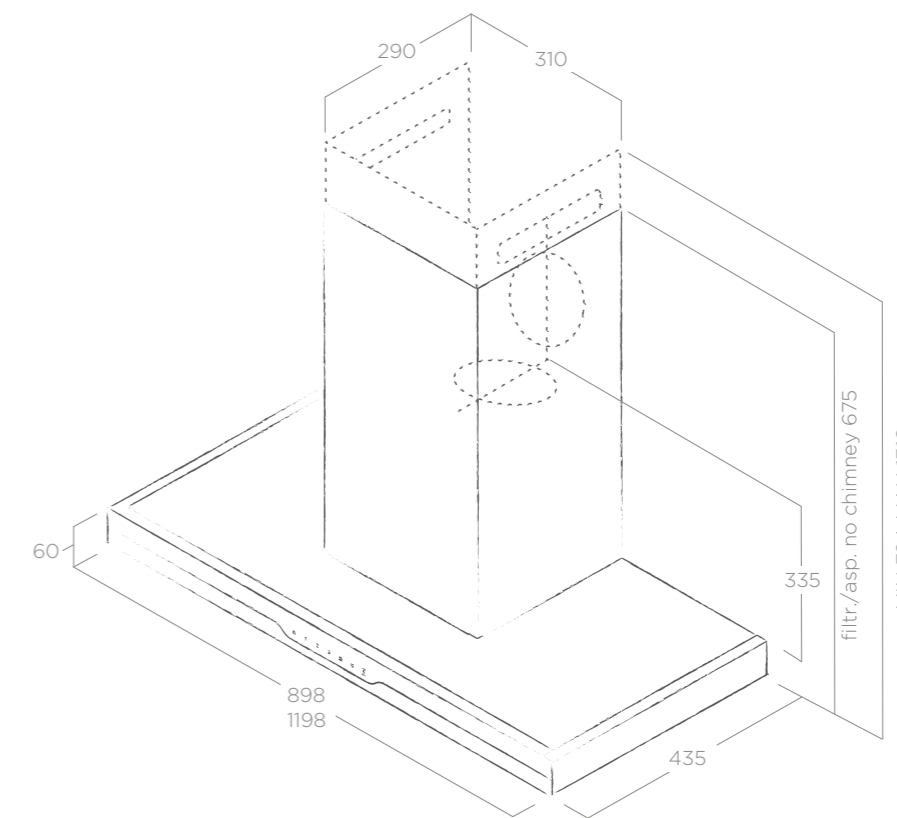

LIGHTING



SILENCE



SMART
INSTALLATION



ENERGY
CLASS



BACK
ASPIRATION



TUNE
WHITE



REVOLUTION
FILTER



CM 50



CM 65

VERSIONE A ISOLA PAG. 137

SCHEDA TECNICA TECHNICAL FEATURES

Misure Size	90 - 120 cm
Versione Version	Aspirante Duct-out
Finiture Finish	Acciaio inox + vetro nero Stainless steel + black glass

ILLUMINAZIONE LIGHTING

Tipo Type	Strip Led 1x7 W
Intensità Intensity	141 LUX
Temperatura Temperature	2700-6000 K

PERFORMANCE PERFORMANCE

Comandi Controls	Touch Control 3V+2I 3S+2B Touch Control
Portata intensiva Booster airflow	757 m ³ /h
Livello sonoro Noise level	59 db(A)
Assorbimento totale Total absorption	317 W
Uscita Duct size	150 mm
Classe energetica Energy class	A (A**/E)

ACCESSORI ACCESSORIES

Revolution filter Revolution filter	CFC0140091
Kit prima installazione filtrante First installation recycling kit	KIT0160440



Possibilità di installazione, in modalità aspirante o filtrante, senza ausilio del camino superiore, restando in un'altezza di 675 mm
Possibility for installation in extraction or filtration mode, without the aid of the upper chimney, remaining within a height of 675 mm

MODELLI MODELS

Filtro grassi alluminio incluso Grease aluminium Filter included

METEORITE IX/A/90	PRF0147272
METEORITE IX/A/120	PRF0147273



SERENDIPITY

DESIGN FABRIZIO CRISÀ

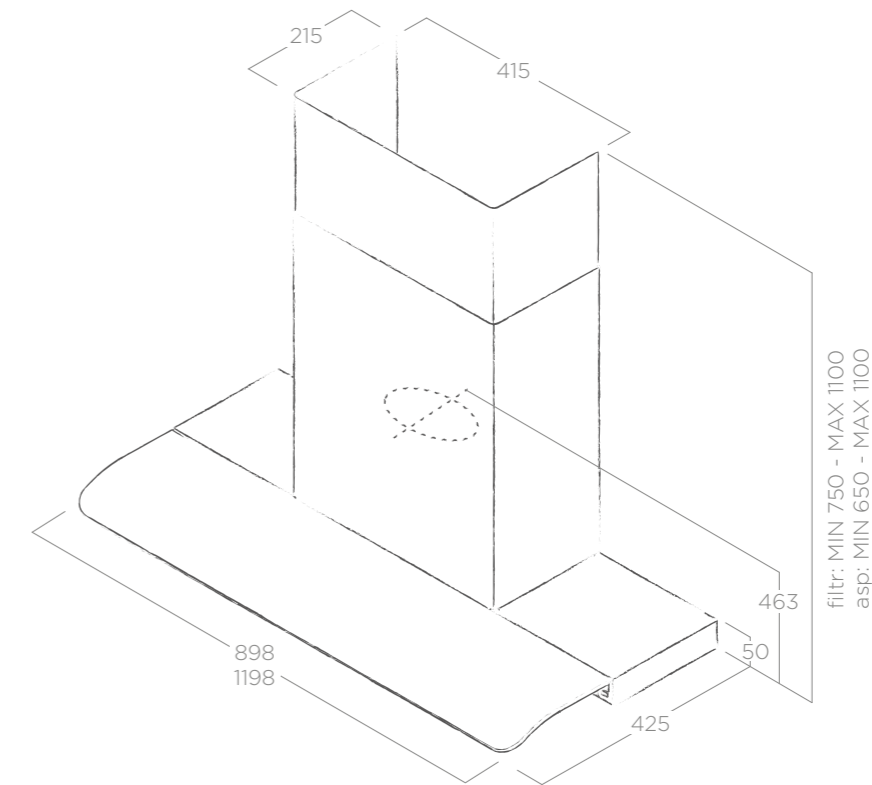

LONG LIFE FILTER



ENERGY CLASS

WALL



CM 50



CM 65

VERSIONE A ISOLA PAG. 139

SCHEDA TECNICA TECHNICAL FEATURES

Misure Size	90 - 120 cm
Versione Version	Aspirante Duct-out
Finiture Finish	Acciaio inox + vetro Stainless steel + glass

ACCESSORI ACCESSORIES

Filtro lunga durata Long Life Filter	CFC0140094
--------------------------------------	------------

ILLUMINAZIONE LIGHTING

Tipo Type	Strip Led 1x7 W
Intensità Intensity	174 (90cm) - 119 (120 cm) LUX
Temperatura Temperature	4000 K

PERFORMANCE PERFORMANCE

Comandi Controls	Touch Control 3V+I 3S+B Touch Control
Portata intensiva Booster airflow	600 m ³ /h
Livello sonoro Noise level	62 db(A)
Assorbimento totale Total absorption	207 W
Uscita Duct size	150 mm
Classe energetica Energy class	A (A**/E)

MODELLI MODELS

Filtro grassi alluminio incluso Grease aluminium Filter included

SERENDIPITY IX/A/90	PRF0120231
SERENDIPITY IX/A/120	PRF0120282



SCHEDA TECNICA TECHNICAL FEATURES

Misure Size	60 - 90 - 120 cm
Versione Version	Filtrante Filtering
Finiture Finish	Acciaio inox Stainless steel

VERSIONE A ISOLA PAG. 141

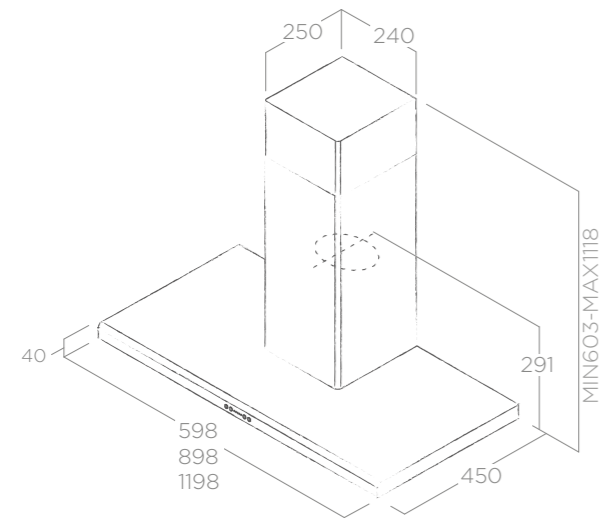

ILLUMINAZIONE LIGHTING

Tipo Type	Neon 14W (60) - 21W (90) - 28W (120)
Intensità Intensity	126 (60CM) - 189 (90CM) - 149 (120CM) LUX
Temperatura Temperature	6500 K

PERFORMANCE PERFORMANCE

Comandi Controls	Touch Control 3V+I 3S+B Touch Control
Portata intensiva Booster airflow	690 m³/h
Livello sonoro Noise level	68 db(A)
Assorbimento totale Total absorption	274W(60) - 281W(90) - 288W(120)
Uscita Duct size	150 mm
Classe energetica Energy class	C (A++/E)

Filtro grassi alluminio incluso Grease aluminium Filter included
Filtro carbone lunga durata incluso Long Life filter included

ACCESSORI ACCESSORIES

Filtro carbone Charcoal Filter	CFC0141529
Filtro lunga durata Long Life Filter	CFC0141725

MODELLI MODELS

MOON IX/F/60	PRF0091764A
MOON IX/F/90	PRF0079550A
MOON IX/F/120	PRF0079551A

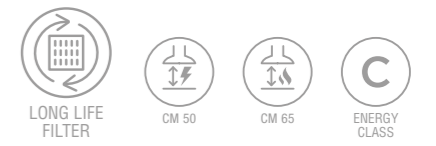

SCHEDA TECNICA TECHNICAL FEATURES

Misure Size	80 cm
Versione Version	Aspirante Duct-out
Finiture Finish	Acciaio inox + vetro bianco/vetro nero Stainless steel + white glass/black glass

VERSIONE A ISOLA PAG. 142

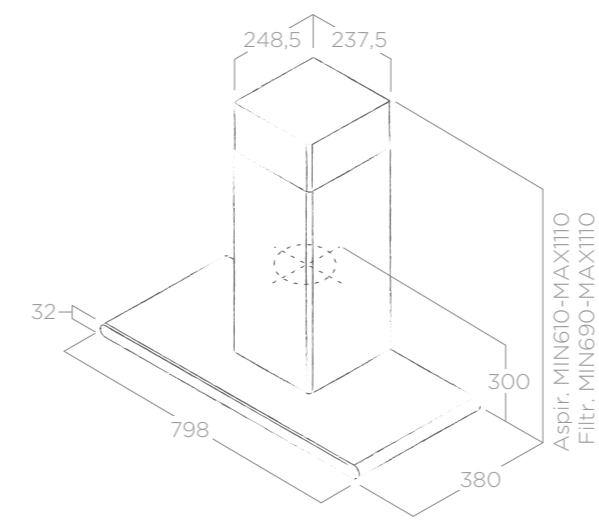

ILLUMINAZIONE LIGHTING

Tipo Type	Led 2x2,5 W
Intensità Intensity	145 LUX
Temperatura Temperature	3500 K

PERFORMANCE PERFORMANCE

Comandi Controls	Touch Control 3V+I 3S+B Touch Control
Portata intensiva Booster airflow	645 m³/h
Livello sonoro Noise level	69 db(A)
Assorbimento totale Total absorption	265 W
Uscita Duct size	150 mm
Classe energetica Energy class	C (A++/E)

Filtro grassi alluminio incluso Grease aluminium Filter included

ACCESSORI ACCESSORIES

Filtro carbone Charcoal Filter	CFC0141529
Filtro lunga durata Long Life Filter	CFC0141725

MODELLI MODELS

GALAXY BLIX/A/80	PRF0008948B
GALAXY WHIX/A/80	PRF0009822B







SWEET PELTROX



SWEET WHITE



SWEET IVORY



SWEET COPPER



SWEET CAST IRON

SWEET

DESIGN FABRIZIO CRISÀ

AWARDS

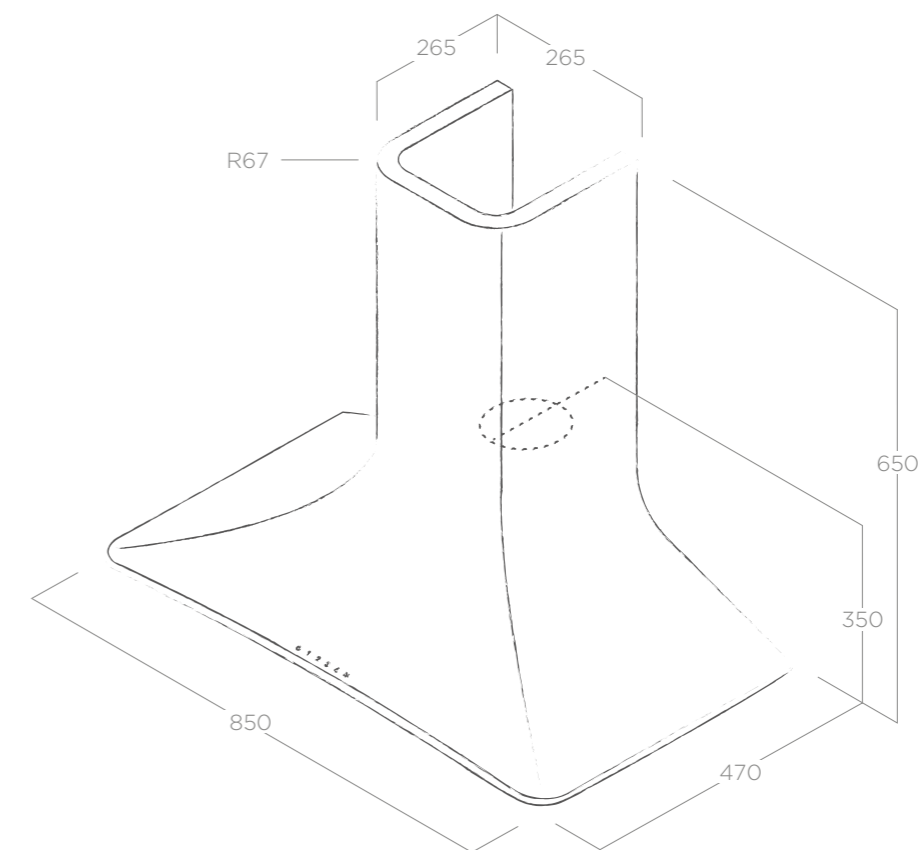

SPECIAL MATERIAL



ENERGY CLASS



SCHEDA TECNICA TECHNICAL FEATURES

Misure Size	85 cm
Versione Version	Filtrante Filtering
Finiture Finish	Verniciature: bianco opaco, tortora opaco, avorio, rame opaco, peltrox, ghisa Painted: matt white, matt umber, ivory, matt copper, peltrox, cast iron

ILLUMINAZIONE LIGHTING

Tipo Type	Strip Led 1x7 W
Intensità Intensity	203 LUX
Temperatura Temperature	4000 K

PERFORMANCE PERFORMANCE

Comandi Controls	Touch Control 3V+I 3S+B Touch Control
Portata intensiva Booster airflow	625 m ³ /h
Livello sonoro Noise level	65 db(A)
Assorbimento totale Total absorption	262 W
Uscita Duct size	150 mm
Classe energetica Energy class	B (A ⁺ /E)

Filtro grassi alluminio incluso Grease aluminium filter included
Filtro carbone lunga durata incluso Long Life filter included

ACCESSORI ACCESSORIES

Filtro lunga durata Long Life Filter	CFC0140426
Kit camino Avorio Chimney kit ivory	KIT0049583
Kit camino Tortora Chimney kit umber	KIT0049581
Kit camino Bianco Chimney kit white	KIT0049580
Kit camino Ghisa Chimney kit cast iron	KIT0121142
Kit camino Rame Chimney kit copper	KIT0121147
Kit camino Peltrox Chimney kit peltrox	KIT0121146



Kit camini speciali a pag. 222
Special chimney kit on page 222

MODELLI MODELS

SWEET IVORY F/85	PRF0043033
SWEET UMBER F/85	PRF0043031
SWEET WHITE F/85	PRF0043030
SWEET CAST IRON/F/85	PRF0120702
SWEET COPPER/F/85	PRF0120672
SWEET PELTROX/F/85	PRF0120689





LOOP

DESIGN FABRIZIO CRISÀ

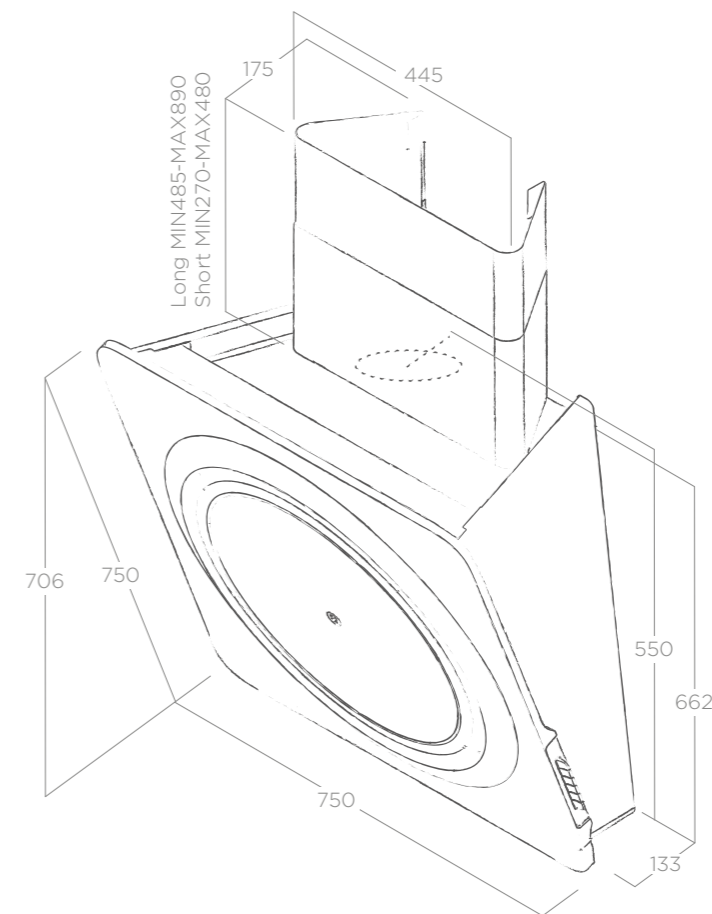

Kit camini speciali a pag. 222
Special chimney kit on page 222

Radiocomando a richiesta. Estetiche disponibili a pag. 235
Kit remote control optional. See page 235 for available design.



LIGHTING



SILENCE



SPECIAL MATERIAL



ENERGY CLASS

SCHEDA TECNICA TECHNICAL FEATURES

Misure Size	75 cm
Versione Version	Filtrante Filtering
Finiture Finish	Cristalplant bianco, Cristalplant nero White Cristalplant, Black Cristalplant

ILLUMINAZIONE LIGHTING

Tipo Type	Strip Led 1x7 W
Intensità Intensity	113 LUX
Temperatura Temperature	2700-6000 K

PERFORMANCE PERFORMANCE

Comandi Controls	Touch Control 3V+2I 3S+2B Touch Control
Portata intensiva Booster airflow	757 m ³ /h
Livello sonoro Noise level	54 db(A)
Assorbimento totale Total absorption	317 W
Uscita Duct size	150 mm
Classe energetica Energy class	A+ (A+/E)

Filtro grassi alluminio incluso Grease aluminium filter included
Revolution Filter incluso Revolution Filter included

ACCESSORI ACCESSORIES

Revolution Filter Revolution Filter	CFC0141803
Kit camino corto Short Chimney kit	KIT0010700
Kit camino lungo Long Chimney kit	KIT0010439
Radiocomando bianco White remote control	KIT0121468
Radiocomando nero Black remote control	KIT0121469



Cristalplant®, materiale ipoallergenico e non tossico, resistente e piacevole al tatto. Grazie alla spugnetta abrasiva inclusa, ogni tipo di 'aggressione' superficiale può essere rimossa, mantenendo inalterato il suo aspetto nel tempo.
Cristalplant®, a hypoallergenic non-toxic material, resistant and agreeable to the touch. Thanks to the abrasive pad, any kind of surface damage can be easily removed while maintaining its original appearance over time.

MODELLI MODELS

LOOP BL/F/75	PRF0147269
LOOP WH/F/75	PRF0147270



CONCETTO SPAZIALE

DESIGN FABRIZIO CRISÀ

AWARDS

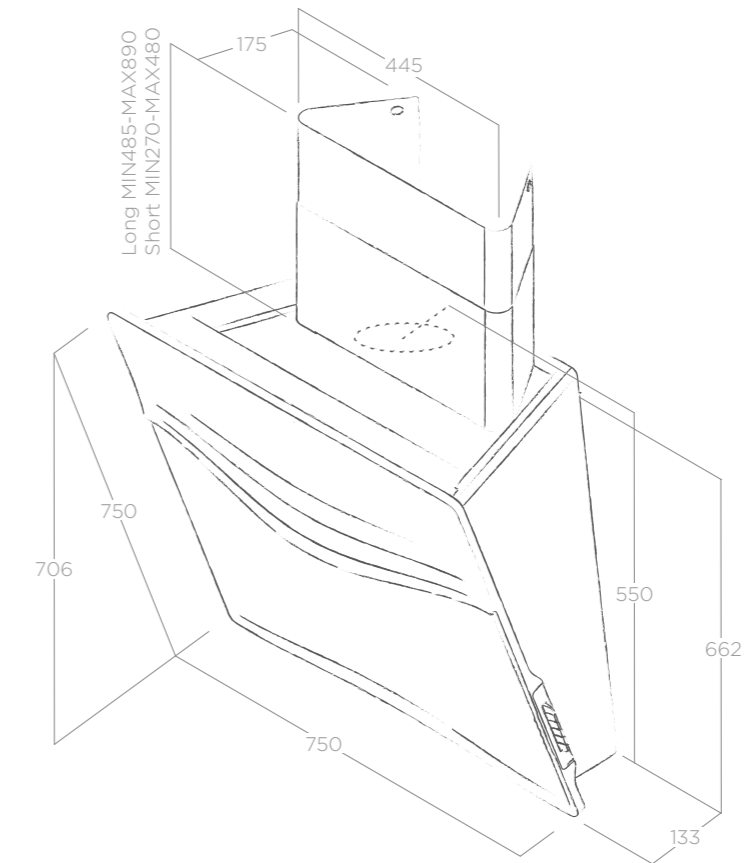

LIGHTING



SILENCE



SPECIAL MATERIAL



ENERGY CLASS



Kit camini speciali a pag. 222
Special chimney kit on page 222

Radiocomando a richiesta. Estetiche disponibili a pag. 235
Kit remote control optional. See page 235 for available design.

SCHEDA TECNICA TECHNICAL FEATURES

Misure Size	75 cm
Versione Version	Filtrante Filtering
Finiture Finish	Cristalplant bianco, Cristalplant nero White Cristalplant, Black Cristalplant

ILLUMINAZIONE LIGHTING

Tipo Type	Strip Led 1x7 W
Intensità Intensity	113 LUX
Temperatura Temperature	2700-6000 K

PERFORMANCE PERFORMANCE

Comandi Controls	Touch Control 3V+2I 3S+2B Touch Control
Portata intensiva Booster airflow	669 m ³ /h
Livello sonoro Noise level	54 db(A)
Assorbimento totale Total absorption	317 W
Uscita Duct size	150 mm
Classe energetica Energy class	A+ (A++/E)

ACCESSORI ACCESSORIES

Revolution Filter	Revolution Filter	CFC0141803
Kit camino corto	Short Chimney kit	KIT0010700
Kit camino lungo	Long Chimney kit	KIT0010439
Radiocomando bianco	White remote control	KIT0121468
Radiocomando nero	Black remote control	KIT0121469



Cristalplant®, materiale ipoallergenico e non tossico, resistente e piacevole al tatto. Grazie alla spugnetta abrasiva inclusa, ogni tipo di 'aggressione' superficiale può essere rimossa, mantenendo inalterato il suo aspetto nel tempo.
Cristalplant®, a hypoallergenic non-toxic material, resistant and agreeable to the touch. Thanks to the abrasive pad, any kind of surface damage can be easily removed while maintaining its original appearance over time.

MODELLI MODELS

Filtro grassi alluminio incluso Grease aluminium filter included
Revolution Filter incluso Revolution Filter included

CONCETTO SPAZIALE BL/F/75	PRF0147267
CONCETTO SPAZIALE WH/F/75	PRF0147268





AWARDS



reddot design award
winner 2016



DESIGN AWARD
2016



NUAGE

DESIGN FABRIZIO CRISÀ

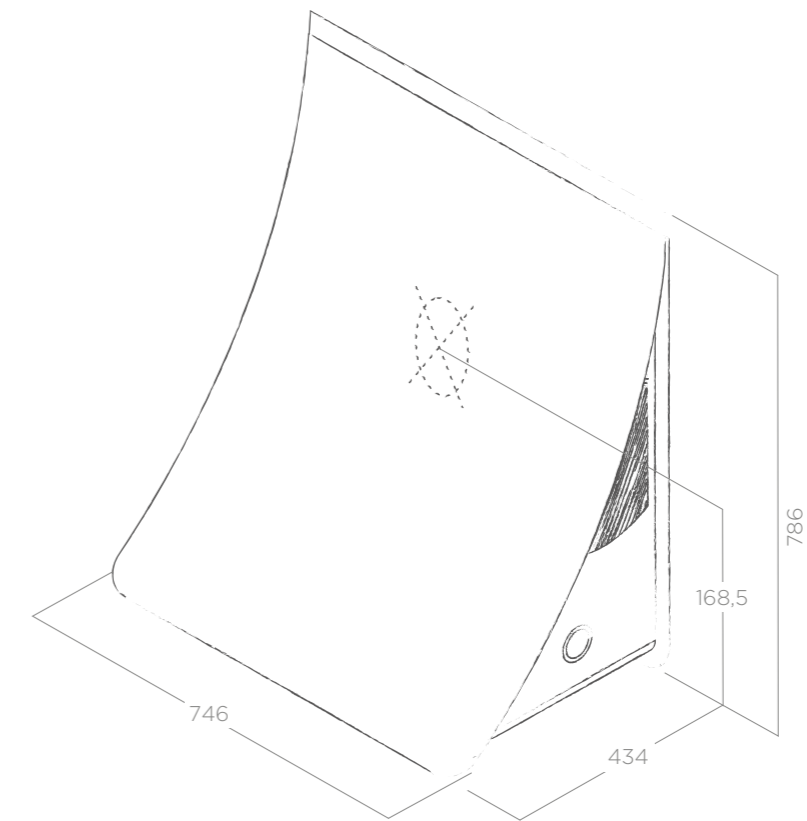

SPECIAL
MATERIAL



ENERGY
CLASS

WALL

SCHEDA TECNICA TECHNICAL FEATURES

Misure Size	75 cm
Versione Version	Filtrante Filtering
Finiture Finish	Acciaio inox AISI 304 pannellabile con cartongesso (non incluso), acciaio inox isi 304 + bianco verniciabile AISI 304 Stainless steel to be paneled with drywall (not included), AISI 304 stainless steel + paintable white

ILLUMINAZIONE LIGHTING	
Tipo Type	Strip Led 1x7 W
Intensità Intensity	147 LUX
Temperatura Temperature	3500 K

PERFORMANCE PERFORMANCE	
Comandi Controls	Rotativo elettronico 3V+I 3S+B Electronic rotary
Portata intensiva Booster airflow	580 m3/h
Livello sonoro Noise level	62 db(A)
Assorbimento totale Total absorption	227 W
Uscita Duct size	150 mm
Classe energetica Energy class	A (A+/E)

Filtro grassi alluminio incluso Grease aluminium filter included
Filtro carbone incluso Charcoal Filter included

ACCESSORI ACCESSORIES

Filtro carbone Charcoal Filter CFC0140343



Modello unico e personalizzabile secondo le esigenze del cliente. Due le versioni disponibili: pannellabile con cartongesso (spessore di 6 mm) o acciaio inox bianco verniciabile. Cartongesso non compreso nella confezione. Le immagini presentate sono esempi di estetiche esclusivamente dimostrative.

Unique model that can be customized according to the customer's needs. Two versions available: with plasterboard panels (6mm thick) or paintable steel. Drywall not included in the packaging. The images shown are only examples of demonstration designs.

MODELLI MODELS

NUAGE DRYWALL/F/75 PRF0096484
NUAGE PAINTABLE/F/75 PRF0098374





FEEL

DESIGN FABRIZIO CRISÀ

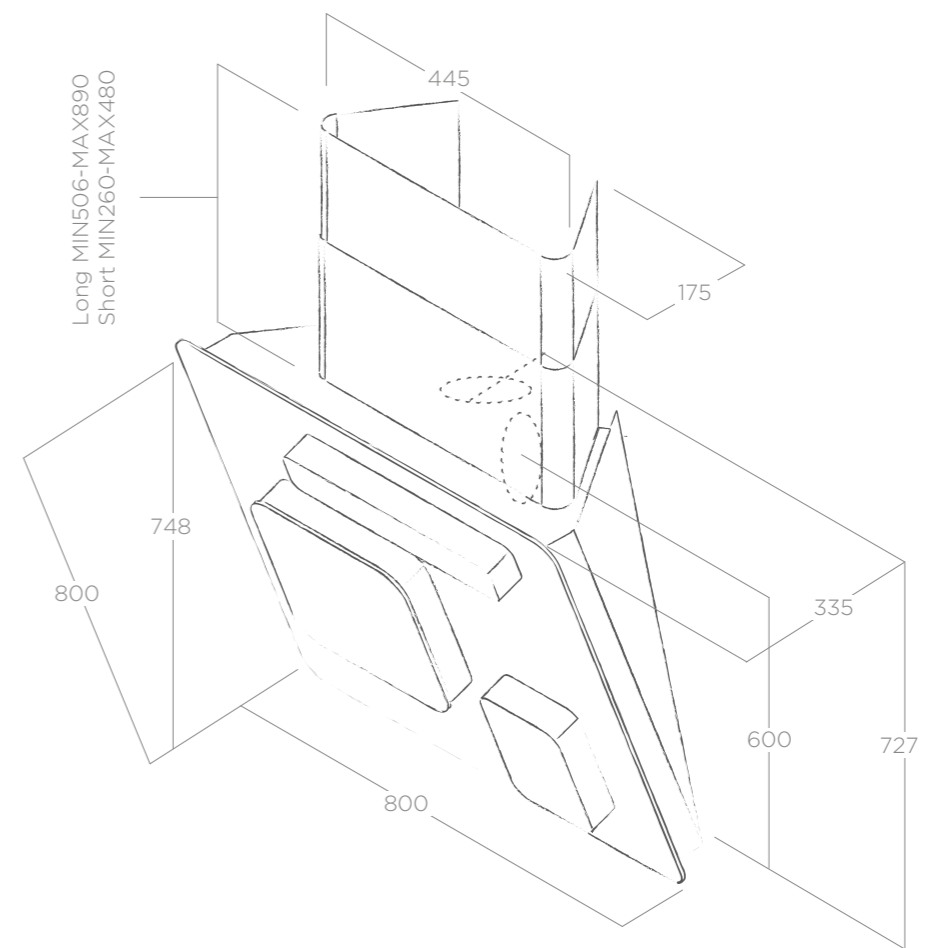

Long MIN506-MAX890
Short MIN260-MAX480



SILENCE



SMART
INSTALLATION



ENERGY
CLASS

WALL

SCHEDA TECNICA TECHNICAL FEATURES

Misure Size	80 cm
Versione Version	Filtrante Filtering
Finiture Finish	Vetro colorato, Coloured glass

ILLUMINAZIONE LIGHTING

Tipo Type	Led 2 x 3,5 W
Intensità Intensity	63 LUX
Temperatura Temperature	4000 K

PERFORMANCE PERFORMANCE

Comandi Controls	E-motion E-motion
Portata intensiva Booster airflow	790 m3/h
Livello sonoro Noise level	58 db(A)
Assorbimento totale Total absorption	307 W
Uscita Duct size	150 mm
Classe energetica Energy class	A (A+/E)

ACCESSORI ACCESSORIES

Filtro lunga durata Long Life Filter	CFC0141720
Kit camino corto Short Chimney kit	KIT0010700
Kit camino lungo Long Chimney kit	KIT0010439

Kit camini speciali a pag. 222
Special chimney kit on page 222

E-MOTION un sistema di controllo naturale e intuitivo.
Il controllo delle funzioni avviene sfiorando i pannelli che si attivano con un movimento elettronico.
E-MOTION the natural and intuitive control system.
Simply touch the electronically activated panels to operate them.

Filtro grassi alluminio incluso Grease aluminium filter included
Filtro lunga durata incluso Long Life Filter included

MODELLI MODELS

FEEL EUPHORIA F/80	PRF0020290B
--------------------	-------------



NO DRIP



NO DRIP

MAJESTIC

DESIGN FABRIZIO CRISÀ

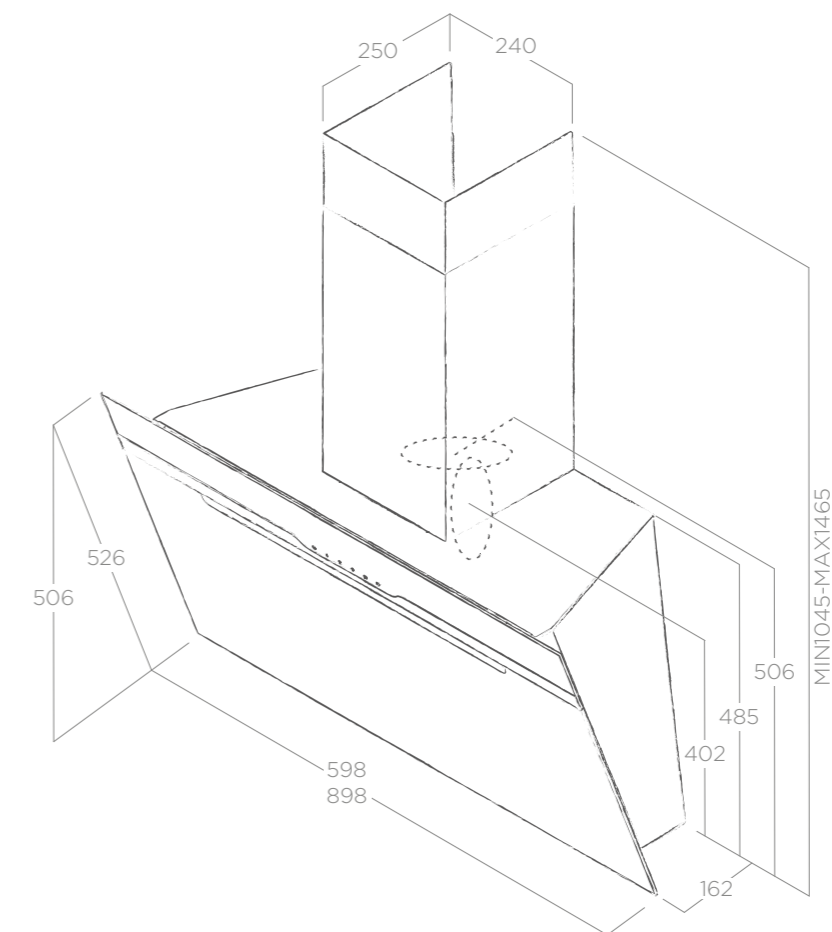

BACK
ASPIRATION



ENERGY
CLASS

WALL

SCHEDA TECNICA TECHNICAL FEATURES

Misure Size	60 - 90 cm
Versione Version	Aspirante Duct-out
Finiture Finish	Acciaio inox + vetro nero, Acciaio inox + vetro bianco Stainless steel + black glass, Stainless steel + white glass

ILLUMINAZIONE LIGHTING

Tipo Type	Led 2x2,5W - Strip Led 1x7 W (No Drip)
Intensità Intensity	145 - 141 (NO DRIP) LUX
Temperatura Temperature	3500 K

PERFORMANCE PERFORMANCE

Comandi Controls	Touch Control 3V+I 3S+B Touch Control
Portata intensiva Booster airflow	690 m ³ /h
Livello sonoro Noise level	65 db(A)
Assorbimento totale Total absorption	255W - 300W (No Drip)
Uscita Duct size	150 mm
Classe energetica Energy class	B (A++/E)

Filtro grassi alluminio incluso Grease aluminium filter included

ACCESSORI ACCESSORIES

Filtro carbone Charcoal Filter	CFC0140343
--------------------------------	------------



NO DRIP: Il vetro si riscalda permettendo alla condensa di vapore di raccogliersi nella parte posteriore ed essere accolto nell'apposito cassetto.
NO DRIP: The glass heats up allowing for vapor condensation to gather in the rear side, where it is collected into a specific drawer.

MODELLI MODELS

MAJESTIC BL/A/60	PRF0117381A
MAJESTIC BL/A/90	PRF0116967A
MAJESTIC WH/A/60	PRF0124235A
MAJESTIC WH/A/90	PRF0124236A
MAJESTIC NO DRIP BL/A/60	PRF0147731
MAJESTIC NO DRIP BL/A/90	PRF0147732



OM AIR

DESIGN FABRIZIO CRISÀ





OM AIR

ELICA DESIGN CENTER

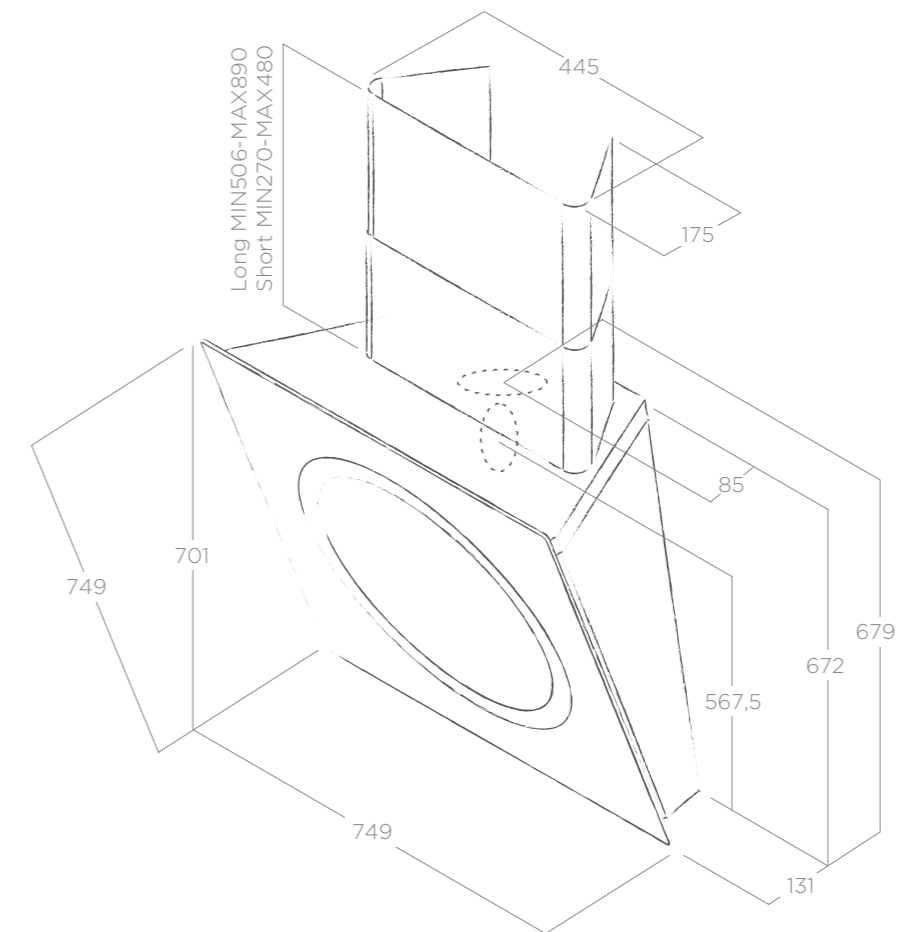

SILENCE



BACK ASPIRATION



ENERGY CLASS



SMART INSTALLATION



CM 45



CM 45

SCHEDA TECNICA TECHNICAL FEATURES

Misure Size	75 cm
Versione Version	Filtrante Filtering
Finiture Finish	Vetro bianco, vetro nero, vetro colorato White glass, Black glass, coloured glass

ILLUMINAZIONE LIGHTING

Tipo Type	Strip Led 1x7 W
Intensità Intensity	119 LUX
Temperatura Temperature	3500 K

PERFORMANCE PERFORMANCE

Comandi Controls	Touch Control 3V+I 3S+B Touch Control
Portata intensiva Booster airflow	665 m ³ /h
Livello sonoro Noise level	60 db(A)
Assorbimento totale Total absorption	247 W
Uscita Duct size	150 mm
Classe energetica Energy class	A (A**/E)

Filtro grassi alluminio incluso Grease aluminium filter included
Filtro carbone incluso Charcoal filter included

ACCESSORI ACCESSORIES

Filtro carbone Charcoal Filter	CFC0140343
Kit camino corto Short Chimney kit	KIT0010700
Kit camino lungo Long Chimney kit	KIT0010439



Kit camini speciali a pag. 222
Special chimney kit on page 222



Al momento dell'attivazione, l'anello centrale si muove elettronicamente verso l'interno consentendo l'aspirazione perimetrale.
Upon activation, the center ring electronically moves inwards, allowing perimeter suction.

MODELLI MODELS

OM AIR WH/F/75	PRF0094734
OM AIR BL/F/75	PRF0094744
OM AIR POP/F/75	PRF0098373
OM AIR BEAUTY/F/75	PRF0100137
OM AIR VINTAGE/F/75	PRF0100138
OM AIR NATURE/F/75	PRF0100231



OM AIR BLACK



OM AIR VINTAGE



OM AIR WHITE



OM AIR BEAUTY



OM AIR POP



OM AIR NATURE



SCHEDA TECNICA TECHNICAL FEATURES

Misure Size	80 cm
Versione Version	Filtrante Filtering
Finiture Finish	Vetro bianco, vetro nero White glass, black glass

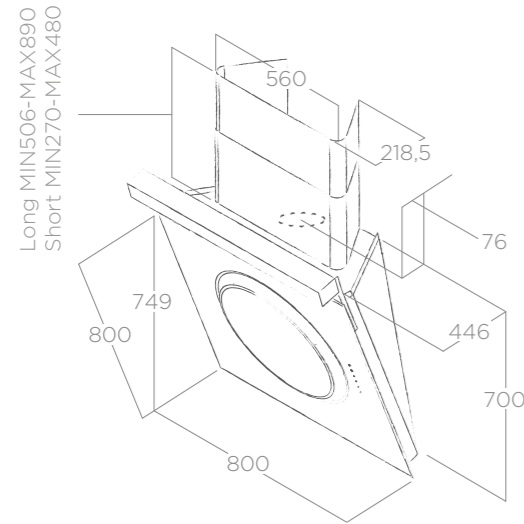

ILLUMINAZIONE LIGHTING

Tipo Type	Led 4x3 W
Intensità Intensity	193 LUX
Temperatura Temperature	3500 K

PERFORMANCE PERFORMANCE

Comandi Controls	Touch Control 3V+I 3S+B Touch Control
Portata intensiva Booster airflow	690 m³/h
Livello sonoro Noise level	59 db(A)
Assorbimento totale Total absorption	262 W
Uscita Duct size	150 mm
Classe energetica Energy class	C (A**/E)

Filtro grassi alluminio incluso Grease aluminium Filter included
Filtro carbone lunga durata incluso Long Life filter included

ACCESSORI ACCESSORIES

Filtro lunga durata Long Life Filter	CFC0140088
Kit camino corto Short Chimney kit	KIT01796
Kit camino lungo Long Chimney kit	KIT01054

MODELLI MODELS

OM TOUCH SCREEN BL/F/80	61612979A
OM TOUCH SCREEN WH/F/80	61612978A

Kit camini speciali a pag. 222
Special chimney kit on page 222

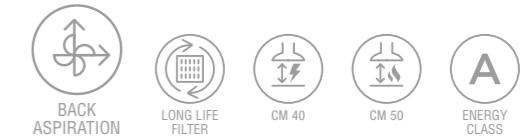

SCHEDA TECNICA TECHNICAL FEATURES

Misure Size	55 cm
Versione Version	Filtrante Filtering
Finiture Finish	Vetro bianco, vetro nero White glass, black glass

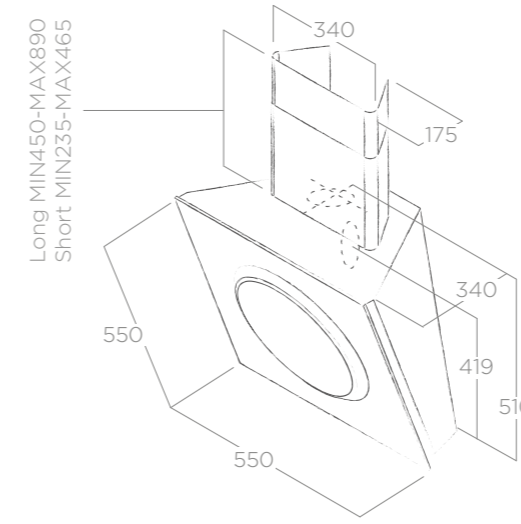

ILLUMINAZIONE LIGHTING

Tipo Type	Led 2x2,5 W
Intensità Intensity	145 LUX
Temperatura Temperature	4000 K

PERFORMANCE PERFORMANCE

Comandi Controls	Pulsantiera Soft Light 3V 3S Soft Light push button
Portata massima Max airflow	600 m³/h
Livello sonoro Noise level	63 db(A)
Assorbimento totale Total absorption	225 W
Uscita Duct size	150 mm
Classe energetica Energy class	A (A**/E)

Filtro grassi alluminio incluso Grease aluminium Filter included
Filtro carbone lunga durata incluso Long Life filter included

ACCESSORI ACCESSORIES

Filtro lunga durata Long Life Filter	CFC0140423
Kit camino corto Short Chimney kit	KIT01797
Kit camino lungo Long Chimney kit	KIT01513

MODELLI MODELS

MINI OM BL/F/55	61614583A
MINI OM WH/F/55	61614584A

Kit camini speciali a pag. 222
Special chimney kit on page 222

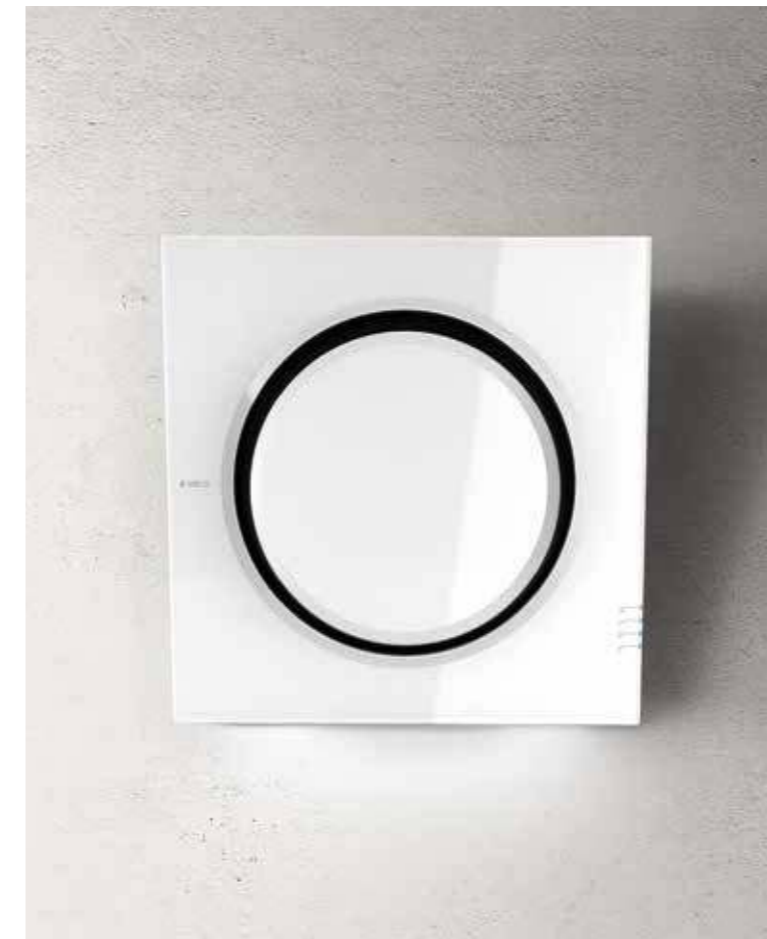

AMÉLIE

DESIGN FABRIZIO CRISÀ



SCHEDA TECNICA TECHNICAL FEATURES

Misure Size	85 cm
Versione Version	Filtrante Filtering
Finiture Finish	Specchio e cornice legno naturale sbiancato Mirror and whitened natural wood frame

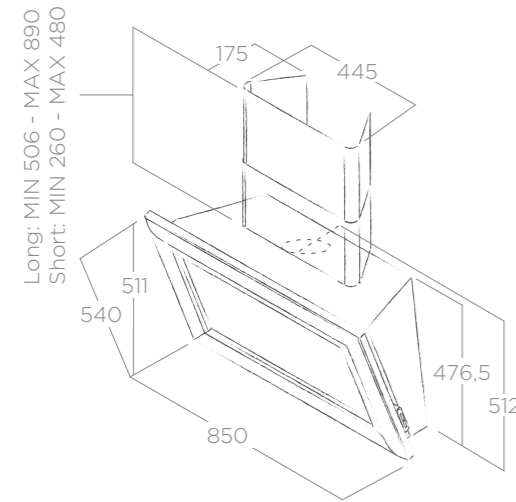

ILLUMINAZIONE LIGHTING

Tipo Type	Strip Led 1x7 W
Intensità Intensity	147 LUX
Temperatura Temperature	3500 K

PERFORMANCE PERFORMANCE

Comandi Controls	Pulsantiera soft light 3V 3S Soft light push button
Portata massima Max airflow	645 m ³ /h
Livello sonoro Noise level	66 db(A)
Assorbimento totale Total absorption	247 W
Uscita Duct size	150 mm
Classe energetica Energy class	A (A**/E)

Filtro grassi alluminio incluso Grease aluminium Filter included
Filtro carbone incluso Charcoal filter included

ACCESSORI ACCESSORIES

Filtro carbone Charcoal Filter	CFC0140343
Kit camino corto Short Chimney kit	KIT0010700
Kit camino lungo Long Chimney kit	KIT0010439

MODELLI MODELS

AMELIE MATWH/F/85	PRF0094413
-------------------	------------

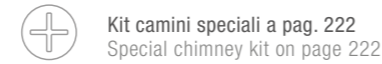

ELLE

DESIGN FABRIZIO CRISÀ



SCHEDA TECNICA TECHNICAL FEATURES

Misure Size	80 cm
Versione Version	Filtrante Filtering
Finiture Finish	Vetro bianco, vetro nero White glass, black glass

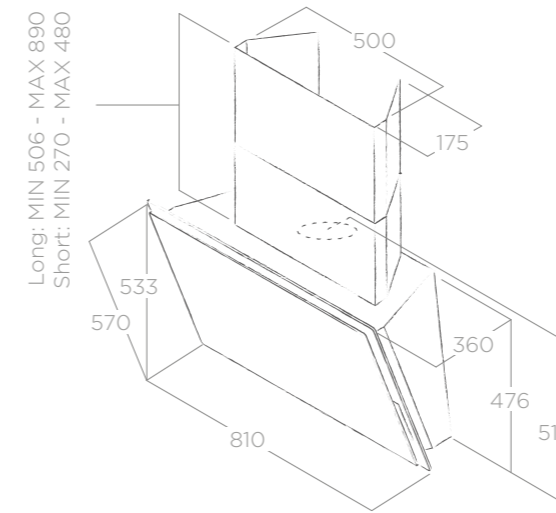

ILLUMINAZIONE LIGHTING

Tipo Type	Strip Led 1x7 W
Intensità Intensity	147 LUX
Temperatura Temperature	3500 K

PERFORMANCE PERFORMANCE

Comandi Controls	Infrared Touch 3V+I 3S+I Infrared Touch
Portata intensiva Booster airflow	665 m ³ /h
Livello sonoro Noise level	62 db(A)
Assorbimento totale Total absorption	247 W
Uscita Duct size	150 mm
Classe energetica Energy class	A (A**/E)

Filtro grassi alluminio incluso Grease aluminium Filter included
Filtro carbone incluso Charcoal filter included

ACCESSORI ACCESSORIES

Filtro carbone Charcoal Filter	CFC0140343
Kit camino corto Short Chimney kit	KIT0010704
Kit camino lungo Long Chimney kit	KIT0010703

MODELLI MODELS

ELLE BL/F/80	PRF0094251
ELLE WH/F/80	PRF0097706

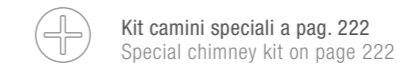

SINFONIA

DESIGN FABRIZIO CRISÀ



SCHEDA TECNICA TECHNICAL FEATURES

Misure Size	80 cm
Versione Version	Filtrante Filtering
Finiture Finish	Vetro bianco, vetro nero White glass, black glass

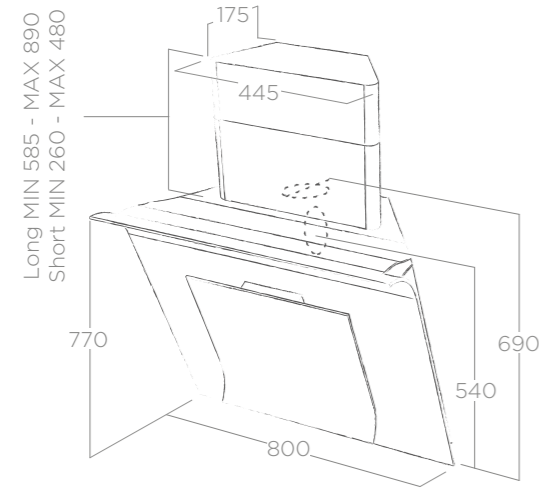

ILLUMINAZIONE LIGHTING

Tipo Type	Neon 2x14 W
Intensità Intensity	84 LUX
Temperatura Temperature	4000 K

PERFORMANCE PERFORMANCE

Comandi Controls	Touch Control 3V+I 3S+B Touch Control
Portata intensiva Booster airflow	755 m³/h
Livello sonoro Noise level	70 db(A)
Assorbimento totale Total absorption	328 W
Uscita Duct size	150 mm
Classe energetica Energy class	B (A++/E)

Filtro grassi alluminio incluso Grease aluminium Filter included
Filtro carbone lunga durata incluso Long Life filter included

ACCESSORI ACCESSORIES

Filtro lunga durata Long Life Filter	CFC0140088
Kit camino corto Short Chimney kit	KIT0010700
Kit camino lungo Long Chimney kit	KIT0010439

MODELLI MODELS

SINFONIA BL/F/80	PRF0010417B
SINFONIA WH/F/80	PRF0010418B

Kit camini speciali a pag. 222
Special chimney kit on page 222

VERTIGO

ELICA DESIGN CENTER



SCHEDA TECNICA TECHNICAL FEATURES

Misure Size	90 - 120 cm
Versione Version	Filtrante Filtering
Finiture Finish	Vetro bianco, vetro nero White glass, black glass

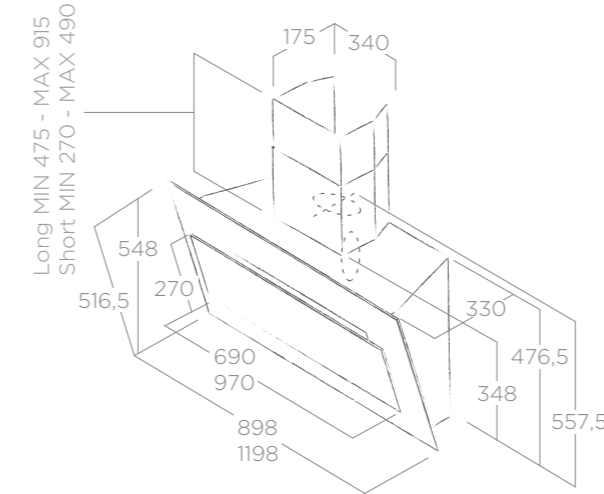

ILLUMINAZIONE LIGHTING

Tipo Type	Led 2x2,5 W
Intensità Intensity	301 LUX
Temperatura Temperature	3000 K

PERFORMANCE PERFORMANCE

Comandi Controls	Touch Control 3V+I 3S+B Touch Control
Portata intensiva Booster airflow	690 m³/h
Livello sonoro Noise level	68 db(A)
Assorbimento totale Total absorption	265 W
Uscita Duct size	150 mm
Classe energetica Energy class	C (A++/E)

Filtro grassi alluminio incluso Grease aluminium Filter included
Filtro carbone incluso Charcoal filter included

ACCESSORI ACCESSORIES

Filtro carbone Charcoal Filter	CFC0140343
Kit camino corto Short Chimney kit	KIT01797
Kit camino lungo Long Chimney kit	KIT01513

MODELLI MODELS

VERTIGO BL/F/90	PRF0079553B
VERTIGO BL/F/120	PRF0079555B
VERTIGO WH/F/90	PRF0079554B
VERTIGO WH/F/120	PRF0079556B

Kit camini speciali a pag. 222
Special chimney kit on page 222





YE

DESIGN FABRIZIO CRISÀ

